

**The Patents Act, 1970**  
**Qualifying Examination under section 126 of the Patents Act**  
**(As amended and updated)**  
**PAPER-11 (PROVISIONS OF PATENTS ACT & RULES)**  
**APRIL, 2008**

Time: 2 1/2 Hours  
Total pages-5

Total marks-100

- Instructions:
1. All questions are compulsory
  2. Marks of each question are indicated at the end of the question
  3. Answers should be precise and to the point by relevant Provisions of the Act and Rules.

**Q.No.1 Answer any six of the following (each question carries 10 marks)**  
**(10X6=60)**

- a) Your client is interested in getting a patent in the shortest possible time in India, inform him about the provisions under the Patent Act and the shortest possible time that will take for getting a patent under the Patent Act, 1970 as amended.
- b) Your client is the owner of a patent in India for an invention "An improved process of preparing ethanol" during his work he finds that by altering the temperature and pressure of the process the yield increases significantly, but does not want to spend all over again to get and maintain a patent, suggest him what procedure can be followed that a protection can be obtained economically.
- c) Your client M/s. Colgate Palmolive wants to know as to when a request for examination has been made and when the first examination report u/s12 has been issued for an application No ABC filed by M/s. Proctor and Gamble which was published in the Patent Office Journal. Take action on behalf of your client to find out the above information.
- d) A Scientist Dr. Kumar working in Reliable Remedies Ltd on the remedies for diabetes finds that a compound X obtained from bitter gourd is very effective in controlling diabetes and approaches you to file a patent for him, inform him with a list of all the documents and the action required to be taken to file such a patent.

- e) A Scientist in Bangalore has developed software for searching images, which she wants to protect in India and through out the world, advise her about the possibilities and the course of action to be taken.
- f) Mr. Singh of Delhi has developed a drug for curing bird flue and wants to protect his invention in India and U.K. advise him regarding eh action he can take.
- g) Your Client X has been manufacturing a compound. A since 1.1.2004, one fine day on 5.1.2007 he gets a notice from Mr. Y that he is infringing his patent take action to protect the interest of your client.

**Q. No. 2** Draft a complete specification in the form according to the Act , along with abstract on the basis of information given by your client – **(40x1=40)**

M/s. X your client has informed as follows : I am in possession of an invention relating to a process for the stereoselective transformation of a diol derivative in to an alcohol derivative via a cyclic sulfite moiety. The method is particularly suitable for the preparation of the D(+) or S isomers of malic acid derivative.. Malic Acid is an extremely valuable chiral starting material for synthesis of chiral agrochemicals and pharmaceuticals etc. the natural L(-) or R malic acid is readily available but unnatural D(+) or S-isomer is difficult to obtain therefore many efforts have been made to prepare optically pure malic acid in the past by such as enzymatic processes, asymmetric transformations of readily available chemical natural products; tartaric acid available in natural L(-) form has been used to prepare unnatural D(+) malic acid. In the prior art D(+) dimethylmalate has been prepared from L(-) Di isopropyl tartarate by direct reduction with samarium iodide to give 99% yield. However, in the known processes expensive and hazardous reagents have been used, and are not amenable to large scale production.

While the structural difference between stereoisomers are subtle and of little consequence in ordinary chemical reactions, they are profound where Biological systems are concerned. Synthesis of compound with asymmetric centers in organic chemistry yield racemic mixtures which are relatively low in bioactivity as certain stereoisomers are likely to be inactive resulting in larger quantities of material to be used to obtain an effective dose. Thus optical purity or enantiomeric excess is a very important consideration in chemical synthesis of optically active compounds. My process obviates the above drawbacks.

The present invention is directed to a process of transforming a compound of formula (I) to a compound of formula (II) in which  $n = 0$  or  $1$ ;  $R_1, R_2, R_3, R_4$  represent independently an H atom,

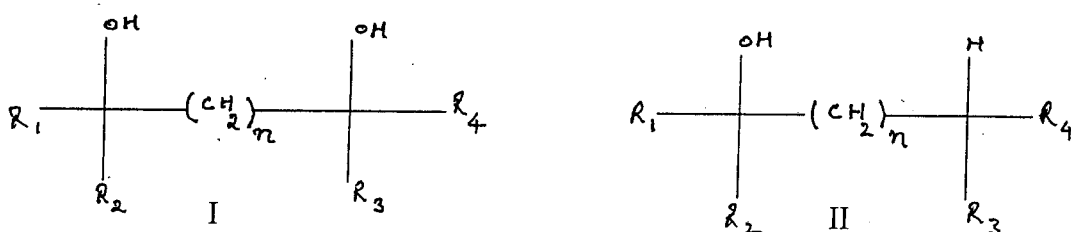

alkyl,aryl, or C-OY where Y=H or Halogen, under effective conditions to form a cyclic sulfite.

The steps of the process are given as follows:(i)Reacting a compound of formula I with thionyl Halide using E.schiller process to form a cyclic sulfite(ii) reacting the cyclic sulfite with a halide salt to form halo substituted acyclic sulfite (iii) reacting the said halide of step(ii) with a reducing agent to obtain the compound of formula (II).

Particularly in an embodiment tartaric acid is transformed to the corresponding cyclic sulfite by reaction with thionyl chloride and the resulting cyclic sulfite is treated with inorganic halide, followed by reduction to give a malic acid derivative.

The procedure is explained with the help of following example.

#### Preparation of D(+) diethyl malate

LiBr (2.6 g, 30 mmol) is added slowly to a cold (ice water bath) solution of (-) diethyl tartrate cyclic sulfite\* (5.1 g, 20mmol) in 20 mL of DME. After addition the mixture is heated to 50 C and stirred for 5 hrs. TLC showed the starting cyclic sulfite is consumed. The mixture is cooled and transferred with the aid of 20 ml of DME to a hydrogenation flask containing 10% Pd/C (1.5 g) and MgO (2,4 g, 60 mmol) in 100 mL of water. The mixture is hydrogenated at 25 C. under 50 psi of H<sub>2</sub> pressure for 30 minutes. The mixture is filtered. The crude product is purified by flash chromatography eluting with 15% EtOAc in hexane to provide the title compound (2.45g, 64%)

\*The tartarate cyclic sulfites are prepared by known procedure (E.Schiller) i.e. step(i)

**OR**

We have invented a portable solar water heater which is not very expensive. Various solar water heaters are available in the prior art but they are bulky and not suitable for transporting however the present water heater has its unique features and advantages.

The invention is illustrated with the help of following drawing

Fig. 1 is a perspective view of the solar water heater with a single parabolic reflector.

Fig. 2 is a perspective view of the solar water heater with a plurality of parabolic reflectors

Fig. 3 is a perspective view of a user employing the air pump to begin the flow of water.

#### DETAILED DESCRIPTION OF THE DRAWINGS

Fig. 1 illustrates a perspective view of the solar water heater 10 having a single stainless steel parabola 40 for collecting sunlight. The solar heater 10 comprises a cylindrical water tank 12 and a substantially cylindrical solar heating compartment 14. The water tank 12 has a top surface 12T,

a bottom surface 12B, a side surface 12S, and a water tank inlet connection 30 and a water tank drain 56, both extending fully through the side surface 12S. The water tank 12 is shown substantially filled with water 44.

The heating compartment 14 has a circular bottom surface 14B which overlaps the top surface 12T of the water tank 12, and a top surface 14T and a side surface 14S which are both constructed from a transparent material such as glass or plastic. The bottom surface 14B is preferably constructed from a material which insulates against heat loss from the water tank 12. The heating compartment 14 has a substantially centrally located cylindrical copper water reservoir 24 having two flat circular end portions 24E and a surface 24S, cylindrical copper water tubing 32 extending from both end portions 24E, and two hot water outlet 26 extending from the water tubing 32 fully through the side 14S of the heating compartment 14, whereby hot water may be released for use.

In an alternative embodiment, a single hot water outlet may be provided. The heating compartment 14 also comprises a single parabolic reflector 40 having a curved upper surface 40U, which is oriented facing upward. The parabolic reflector 40 is constructed from highly reflective stainless steel and causes the incident rays of sunlight to be reflected and converged at a focal point of the parabola substantially upon the surface 24S of the water reservoir 24. In this regard, the copper which is used for the water reservoir 24 should preferably not be highly reflective, because it is desirable that most of the light which is reflected from the parabolic reflector 40 should be absorbed by the water reservoir 24 in order to maximize the heating efficiency of the solar water heater 10.

The solar heater 20 further comprises an air pump 16, in communication with the water reservoir 24 and the water tubing 32 extending there from. The air pump 16 has an air pump handle 20, vertical air pump tubing 22 V, and horizontal air pump tubing 22H. The air pump 16 creates a partial vacuum in the water tubing 32, thereby causing water to flow from the water tank 12 into the water reservoir 24 and the water tubing 32. Once the siphoning of water has begun, the air pump 16 is no longer needed to maintain a flow of water. Water will continue to flow from the hot water outlets 26 of the solar water heater 10 until the partial vacuum is released by opening the air pump tubing to the atmosphere. In order that the flow of water from the solar water heater 10 remains uninterrupted, the hot water outlet 26 is generally connected to hose having an outlet which is maintained at a lower level than the water 44 in the water tank 12, thereby preventing the siphon from "breaking". An electric pump may be utilized instead of a manual air pump.

Fig 2 shows an alternate design where the solar water heater comprises a plurality of parabolic reflectors instead of once large parabolic reflector, and instead of centrally located water reservoir 24 in fig 1 there is a convoluted stretch of water tubing. The parabolic reflectors are situated at positions which result in the reflected light to converge on different portions of the surface of the tubing, in this design only one water outlet is present.

Fig 3 shows a user initiating the water flow from the water tubing 32 by creating a partial vacuum in the tube 32 by pressing and releasing the air pump handle 20, once the stream 46 has started it will continue till the tank becomes empty or the siphon effect is broken or releasing the tubing to atm pressure.

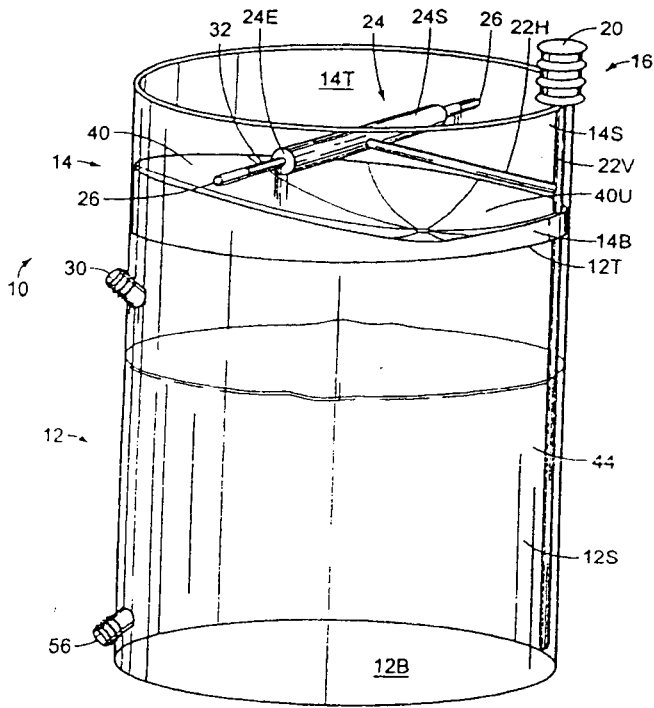

Fig. 1

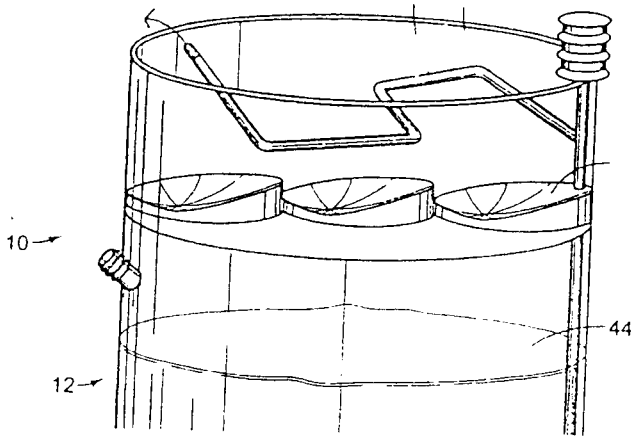

Fig. 2

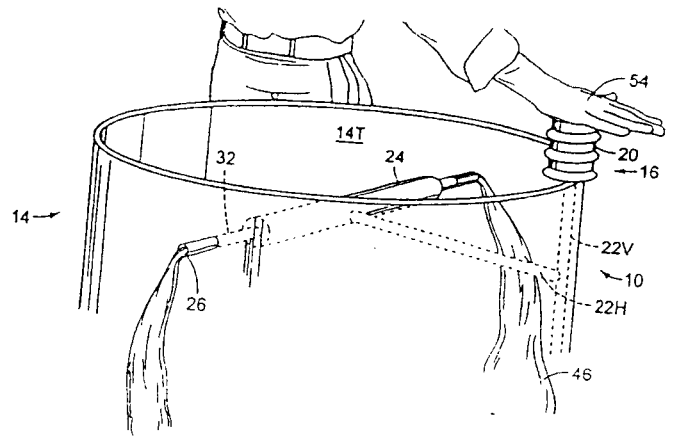

Fig. 3